

MANUFACTURING MATTERS

October 2016 | Issue 4

A publication of the Singapore Institute of Manufacturing Technology

FEATURE

MANY CHOICES TO SUIT YOUR PRODUCTIVITY NEEDS

SUCCESS STORY
T-UP Jumpstarts In-house Innovation

SKILLS MATTERS
INDUSTRIAL TRAINING REDEFINED

PE MATTERS
CREATE FUNCTIONAL SURFACE WITH ADVANCED SURFACE COATING TECHNOLOGY

RESEARCH SPOTLIGHT
New Manufacturing Technology Packs **MORE ENERGY** into Asymmetric Supercapacitors

NOTE FROM EDITOR...

Dear Friends and Industry Partners,

The Manufacturing Productivity Technology Centre (MPTC), set up in 2011 at SIMTech, has made its mark on Small and Medium Enterprises (SMEs) and Multinational Corporations (MNCs). It has assisted companies to develop and adopt technology and innovation to enhance productivity for effectiveness, greater efficiency and engineer value creation. The centre achieved these through 11 initiatives rolled out by MPTC with new initiatives being launched to address industry's changing needs. Aware of SMEs' specific requirements, an array of ready-to-go technologies are introduced for mass adoption (see opposite Feature for details).

To reach out to more industries, MPTC is exploring new collaboration with the Singapore Workforce Advancement Federation. MPTC is already working with the Association of Singapore Marine Industries, the Singapore Chinese Chamber of Commerce and Industry and Singapore Manufacturing Federation.

Swee Heng

Editor, Manufacturing Matters

Email: shlee@SIMTech.a-star.edu.sg



MANY CHOICES TO SUIT YOUR PRODUCTIVITY NEEDS

Initiatives are introduced and various ready-to-use solutions, methodologies and technologies are available for mass adoption by industry

SIMTech engages industry to understand their productivity challenges. Arising from this, initiatives which are common technology platforms applicable to solving similar needs of many companies are formulated. Four such initiatives, **wfMobile™**, **Collection and Delivery Management System (CDMS)**, **Manpower Scheduling System** and **Inventory Planning System** are rolled out recently.

Initiatives

wfMobile™, an App, provides faster, cheaper and better solution for on-the-go workforce to perform transactions remotely. Sales staff, drivers, construction crew can use this ready-to-go App for real-time update of their remote activities for central visibility and planning purposes. Workflow cycle time, tracking effort and paper work are expected to reduce by 30, 60 and 90 per cent respectively. The low-cost mobile workflow on Android devices is readily configurable for business and operational transactions. It can be applied to other areas in the company business.

The **Collection and Delivery Management System (CDMS)** provides a simple and affordable solution for drivers of courier and logistics companies to deliver the right items to the right customers on time. The administrative officer in the office tracks and receives updates from driver's daily activities in real-time with optimal resource and task management, eliminating inaccuracies and inefficiency from manual handling. Companies benefit from efficient delivery tasks management, optimal resource utilisation, real-time tracking and visibility, smart delivery advice, reduce mis-deliveries and improve information accuracy. Operations costs, time and effort are expected to save by 20 per cent using this system.

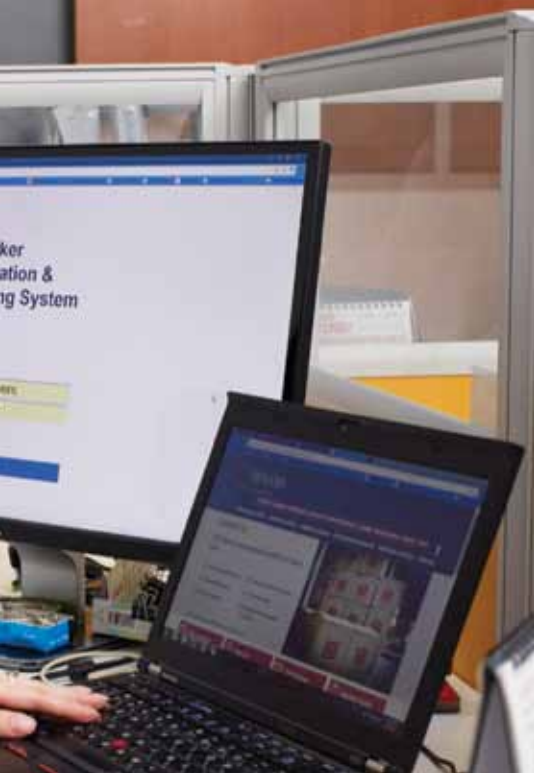

The **Manpower Scheduling System** allows users to automatically generate shift schedule and allocate manpower with various time slots, workload, skill-sets and location to improve labour productivity, minimise labour cost and increase customer service, complying with employees' welfare at the same time. The one-click automated solution reduces scheduling effort by 80 to 90 per cent. As it optimises the use of manpower, the system avoids over-scheduling or under-scheduling that induces high labour cost or impact customer service level respectively. This system is ideal for the logistics, engineering services, aerospace, manufacturing, construction, retail, healthcare and hospitality sectors.

The **Inventory Planning System** equips companies with the knowledge, skills and systems of inventory planning and policy development to control inventory properly and efficiently, maximising inventory investment return effectively. This capability is achieved as the system provides what-if analysis and policy optimisation function. The system is especially useful as it enables top management and functional heads achieve a common inventory performance. The inventory level and planning time reduction are expected at 40 per cent and surpass 50 per cent respectively. The distribution, manufacturing and retail sectors are the beneficiaries of this system.

Ready-to-Go Solutions

For SMEs which need to address their specific productivity requirements, ready-to-go technologies are available for adoptions. More than 1,600 technology adoptions by 1,090 companies, with a minimum of 20 per cent productivity improvements, have taken place. Some of these technologies are:

ePayslip Generator, capable of calculating CPF contribution rate, skills development levy auto-calculation and e-submission, helps micro-SME employers to issue itemised payslips to employees.

E-Beacon Tracker, a Bluetooth tracking system, enables automatic and instant tracking of job status. It records the time spent for each job or task, leading to better manpower deployment and utilisation.



eDataLogger is an electronic data logging and report generation capability using technology and Android apps to generate an immediate final report with proper formatting including photos on company letterhead without backend office support.

Item Management Tracking System (IMTS)/Inventory Tracking System (ITS) is a RFID and barcode-based technology for better management, tracking and audit of companies' inventory and assets to improve productivity, traceability and minimise errors.

RFID-based Field Worker Identification & Tracking System (FIT) provides timely information on the whereabouts of workers on sites anytime, anywhere, eliminating manual paper recording and data entry.

Near Field Communication-based Asset Management System based on NFC/QR code to provide an asset management solution for SME individual users.

Example of FIT Adoption

One of the companies which adopted FIT is CYC Movers, a specialist in the provision of international and domestic relocation solutions for families and organisations, freight, warehouse solutions, last mile deliveries and reverse logistics. FIT provides a fast and easy way to trace attendance record, eliminating the 2-hour monthly attendance verification and another 2 hours to key in data.

“ The improved accuracy of attendance data reduces the number of payroll processing and overtime claim errors ”

Mr Bernard Chua
Managing Partner, CYC Movers

Example of eDataLogger Adoption

MegaChem Manufacturing Pte Limited, one of the leading chemical contract manufacturers in Singapore, used eDataLogger in the monitoring of maintenance activities, quality assurance reporting and even its visitor logs. Productivity improvement of more than 20 per cent is reported in some of the application areas.



For enquiries, please contact
Dr Lee Eng Wah, Director of MPTC
Email: ewlee@SIMTech.a-star.edu.sg
Web: www.SIMTech.a-star.edu.sg/MPTC

MPTC Manufacturing Productivity
Technology Centre
Enhancing Manufacturing Productivity



Scan for more information on
Manufacturing Productivity
Technology Centre



T-UP JUMPSTARTS IN-HOUSE INNOVATION

During the T-Up* of Mr Ao Yintai at LHT Holdings Limited, a public listed manufacturer of wooden pallet/crate and fabricator of technical wood from recycled waste wood materials, he developed the business activity monitoring (BAM) tools and business process management (BPM) system for pallet manufacturing.

The developed raw material management system and BAM tools automate repetitive processes, eliminate paper-based transactions and

reduce error-prone manual calculation, laborious and time-consuming data entry. With these, LHT management can constantly monitor business performance and track the status of the activity at all times, even outside of the office.

The developed event-driven BPM system is deployed to manage LHT's business processes such as customer profile, quotation, sales order, job order, delivery order, finished goods inventory, piecework-based wage calculation and

so on. The event-driven system enables LHT to monitor, analyse, and respond to changing business conditions in real-time — as events occur.

The BPM system reduces cycle-time and time-to-market. Business cost from the use of electricity, paper and raw material achieves annual saving of up to \$30,000. Manpower savings on inventory management, reduced rework of wage calculation based on pallet pieces, repetitive data entry and possible order delay are estimated at \$30,000, \$20,000 and \$50,000 per year respectively. Revenue is increased by 10 per cent through deploying more advanced machines, ensuring timely visibility and better control of processes.

“ These outcomes are LHT’s continuous effort to improve and innovate its business and pallet manufacturing. Higher throughput is achieved by simplifying processes and enhancing productivity ,”

Ms May Yap, Executive Director, LHT Holdings

**Technology for Enterprise Capability Upgrading (T-Up) is A*STAR’s initiative to second its researchers to local enterprises for a period of time to assist them in their R&D activities.*

For enquiries on T-Up, please contact Mr Cedric Yon at xyyon@SIMTech.a-star.edu.sg

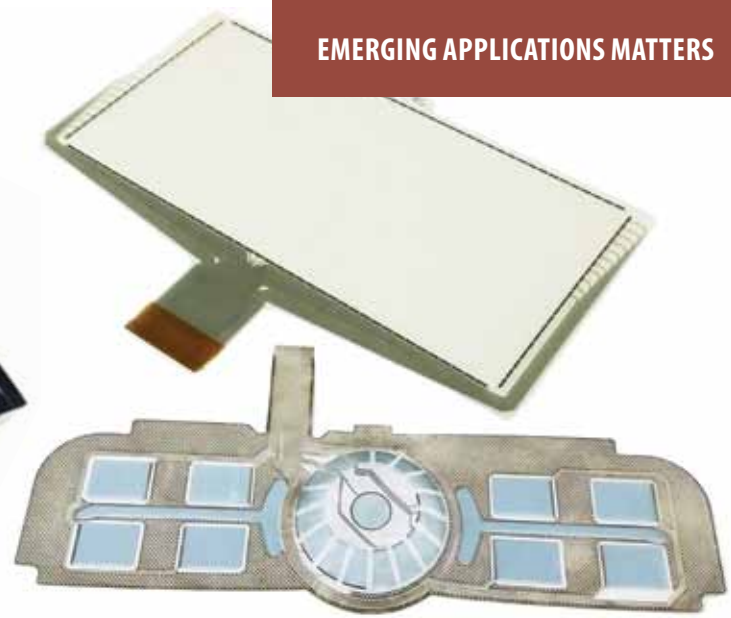

RECONFIGURABLE AUTOMOTIVE PART USING PRINTED ELECTRONICS TECHNOLOGY

The technology enables parts customisation and enhances drivers' experience

Automakers face challenges from global customers with various requirements and designs for infotainment faceplate, forcing them to produce a large variety to meet customer expectations. To help a European multinational automotive part supplier to overcome this challenge, SIMTech adopted printed electronics technology to facilitate the development of a new generation reconfigurable passenger vehicle infotainment faceplate that can adapt to customisation.

A typical infotainment faceplate consists of more than 20 parts of buttons and knobs. Each part, formed by a mould with tight tolerance, is costly. SIMTech developed for the collaborator printed touch sensing film and printed electroluminescent lighting for backlighting the buttons from design to fabrication. Through this project, partnering with local precision

plastic engineering solution provider, Sunningdale Tech Limited, using the 3D formed printed touch buttons and dial, the faceplate is manufactured in one tool. Huge cost saving in tool making is achieved. Customer who requires varied faceplate designs benefits from faster turnaround time as the faceplate is reconfigurable. The touch buttons and dials illuminated by printed lighting give faceplates a sleek and thin appearance.

This project fosters a tripartite partnership to establish local business-technology eco-system comprising a business driver (automotive MMC), local PE manufacturer (Sunningdale) and technology partner (SIMTech) to successfully demonstrate the innovative approach

to reconfigure the touch buttons according to their preferences on the functions usage. Frequent defined functions can be assigned to the specific touch buttons. Drivers can emulate the gesture of turning knob on the 3D touch dial to adjust the volume or search for broadcasting channel. The 3D touch buttons and dials assist drivers in locating them without taking their eyes off the road, enhancing drivers' safety compared to the conventional flat touch screen.

3D printed touch and printed lighting can also be applied onto the control panel of medical equipment, home appliances for hygiene purpose and ease of maintenance. It functionalises conventional plastic surfaces into new interactive platform to enhance user experience.

The integrated demonstrator was showcased in CES 2016, Las Vegas, USA.

For enquiries, please contact
Mr Rick Yeo, Director of EAC
Email: rickyeyo@SIMTech.a-star.edu.sg

EAC Emerging Applications Centre
Seeding and Growing Emerging Industries



Conventional infotainment faceplate
Source: MacDermid

Such faceplate finishing gives the consumer a new experience in the control of infotainment system functions with seamless touch covering most of the surfaces from screen to knobs and buttons. Drivers are able

CREATE FUNCTIONAL SURFACE WITH ADVANCED SURFACE COATING TECHNOLOGY

Collaborative Industry Project to build capability in surface technology to tap market potential

Surface coating is one of the key post processes to enhance product performance in many applications in different sectors of the industry.

The functional coating technologies are applicable on a variety of materials such as: Steels, aluminium alloys, nickel-based alloys, tungsten carbide, silicon and many of the polymeric substrates, and even non-rigid materials such as fabrics and leathers. Coating technologies are relevant to a variety of industries such as PE, marine, automotive, aerospace, oil and gas, marine, MedTech, and construction and infrastructures, etc. Below are some of the advanced applications of surface coatings:

- Surface chemical modification and coatings for metals and polymers, ceramic and glasses
- Smart switchable hydrophobic and superhydrophilic surfaces, easy clean energy coatings, in-channel modification for Microfluidic Manufacturing
- Anti-fouling structures and process

- Photochromic coatings/Infra-Red shielding coatings
- Anti-ice coating
- Transparent conductive coating
- Barrier coatings
- Integrated functional coatings
- Bio-functional coatings: anti-microbial coatings, bio-compatible coatings, anti-body grafted surfaces, drug eluting surface coatings

To enable industry to apply this technology for the diverse market, SIMTech launched a **Collaborative Industry Project (CIP)** on Functional Surface Coating Technology to help companies develop, apply and transfer technology know-how of advanced surface functional coating processes and materials via sol-gel, plasma-assisted grafting and self-assembly-assisted-grafting technologies to create new desired surface functionalities and/or achieve improvement of existing functional performance on surfaces, components and products on rigid or non-rigid metallic, ceramic, polymeric, glass materials, fabrics and leathers.



The scope of this CIP includes:

- Development of coatings for desired surface functional performance
- Provision of technical support on surface coating processing and applying the developed surface coating onto the industry partner's products

For enquiries, please contact
Dr John Yong, Director of PE COI
 Email: msyong@SIMTech.a-star.edu.sg
 Web: www.SIMTech.a-star.edu.sg/PECOI

PE COI Precision Engineering
 Centre Of Innovation
Sustaining and Advancing PE Industry



Scan for more information
 on Precision Engineering
 Centre of Innovation

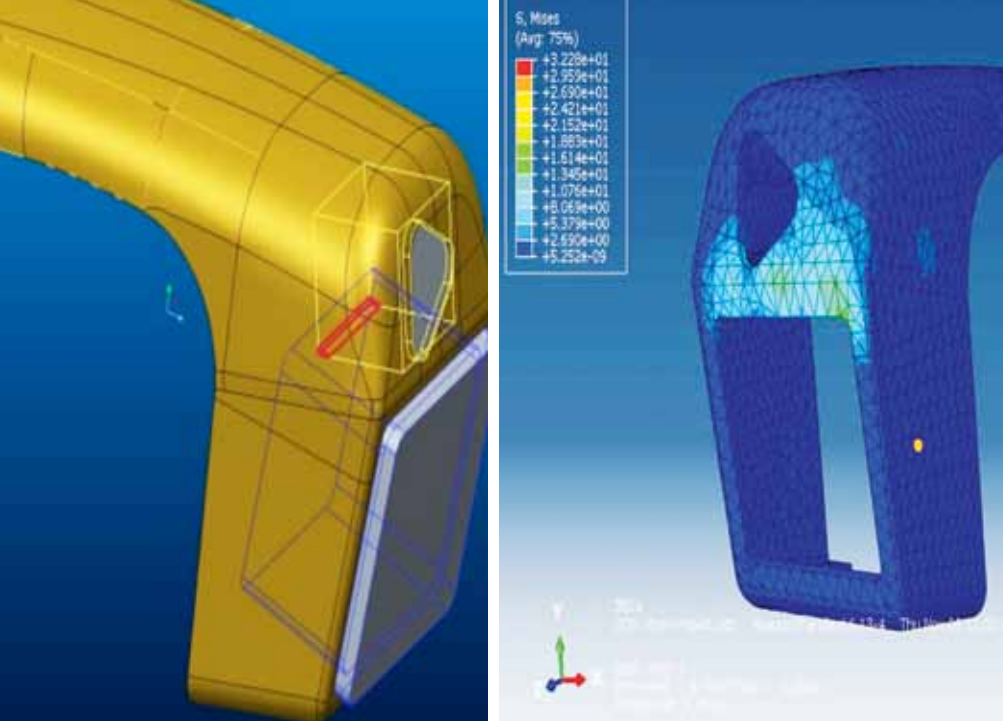

LIGHTWEIGHT MANUFACTURING TECHNOLOGY FOR TRANSPORTATION INDUSTRY

Collaborative Industry Project develops technologies in lightweight material processing for transportation applications and enhances local companies' capabilities

Despite an increasing use of lightweight materials in the transportation, electronics and construction sectors due to its many benefits, processing lightweight materials poses many challenges to industry. Responding to industry needs, SIMTech sets up

Lightweight Manufacturing Initiative to develop advanced technologies to improve lightweight materials applications and processing. The initiative identifies needs and gaps in lightweight related technologies, provides technical support for industry

development through company-specific projects, consultancy services and Collaborative Industry Projects (CIPs).

One of the Lightweight Manufacturing Initiative efforts is the recently completed second CIP with SIA Engineering Company (SIAEC) and four local SMEs to manufacture polymeric aircraft cabin components. During this CIP, SIAEC and the SMEs participated in mould design and fabrication, injection moulding process development and control, heat stake process and spray coating. SIMTech provided consultancy to these companies on the strict aviation materials and process requirements, assisting them to set up quality control systems. All the four SMEs have been audited and approved as SIAEC's service providers which offer an avenue for them to participate in the aviation industry business. Two additional SMEs were qualified to be SIAEC's service providers in this CIP, enlarging the pool of local suppliers in the value chain and creating the foundation for the localisation of aircraft cabin component manufacturing in Singapore.

For enquiries, please contact **Dr Chen Wei Long**, Director of SMC
 wlchen@SIMTech.a-star.edu.sg
 Web: www.SIMTech.a-star.edu.sg/SMC

SMC Sustainable Manufacturing Centre
 Embracing Sustainable Manufacturing

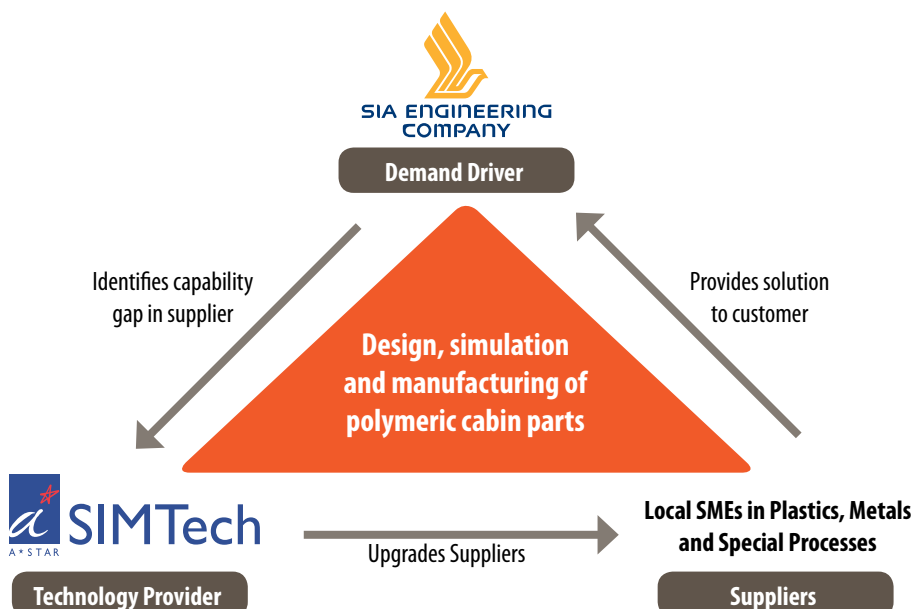

Scan for more information on Sustainable Manufacturing Centre



INDUSTRIAL TRAINING REDEFINED

New training initiatives and programmes are introduced to meet industry needs

With the fast changing technology and manufacturing landscape, Professionals, Managers, Engineers and Technicians (PMETs) have to constantly broaden their existing knowledge, acquire new skills and capabilities and build on new experiences to remain relevant and competitive. With the roll-out of the SkillsFuture framework as a national initiative, the Singapore government helps Singaporeans as well as employers, particularly the local SMEs, to upgrade their knowledge and skills, and promote life-long learning to stay competitive.

To help PMETs, SIMTech through partnership with the Workforce Development Agency (WDA) of Singapore aligns our Workskills Qualification training programmes with the SkillsFuture framework

Courses are designed and restructured to focus on skills utilisation, strengthening the Learn-Practise-Implement course delivery model with emphasis on Workplace Learning, and implementing blended learning focusing on e-Learning system for easy accessibility and learning convenience anytime, anywhere. With the support from WDA for establishing this e-learning platform, four new WSQ courses: graduate diploma in 3D Additive Manufacturing, modular programmes in industrial automation, microfluidics manufacturing technologies and roll-to-roll printing for large area processing, including 5 new WDA Master Classes are launched. All these courses are eligible for using SkillsFuture Credit.

To date, 21 WSQ training programmes have been launched to transfer SIMTech's knowledge, technology and capabilities to the industry through case-based studies and hands-on training. The WSQ training programmes based on an innovative Learn-Practise-Implement model, helps to transfer and implement effectively SIMTech's cutting-edge knowledge and technology for industrial application or adoption.

Through adopting this training model, productivity improvement ranging from 10 to more than 200 per cent has been achieved by our programme participants. More than 10 WDA Master Classes were conducted by internationally renowned experts. These classes enable companies to adopt emerging innovative technologies and capture new business opportunities.

To ensure that our training topics are up-to-date, partnerships with industry associations are forged to understand and identify industry requirements to design and contextualise relevant training topics and contents. In this regard, SIMTech has established collaborative partnership with nine associations, with more ongoing discussions underway.

For more information, please contact **Dr Zeng Xianting** at xzeng@SIMTech.a-star.edu.sg

KTO Knowledge Transfer Office
Enriching Industry Training



Scan for more information on SIMTech Knowledge Transfer Office

Iron Nitrides at Graphene Nanosheets (Fe₂N@GNS)

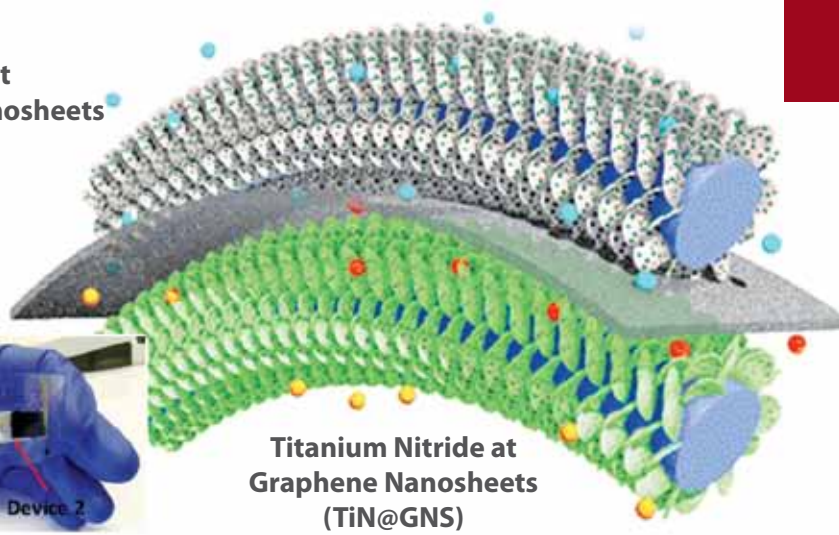
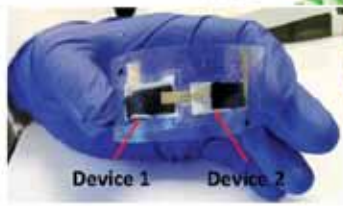

Titanium Nitride at Graphene Nanosheets (TiN@GNS)

Microstructure of metal nitride ASCs. [1]

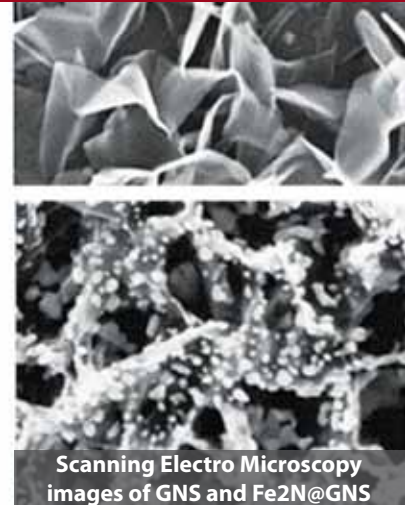

Scanning Electro Microscopy images of GNS and Fe₂N@GNS

NEW MANUFACTURING TECHNOLOGY PACKS MORE ENERGY INTO ASYMMETRIC SUPERCAPACITORS

This alternative overcomes the limited energy stored in supercapacitor

Battery is the common choice to electrochemically store energy. However, it is constrained by the limited number of times that can be charged and discharged. Supercapacitor is an alternative emerging technology that has the capability of fast energy delivery and ultra-long cycle life. Its drawback is with the energy that can be stored in a device of a certain size. It is much smaller in a supercapacitor than it is in a battery. A promising solution is to form asymmetric supercapacitors (ASCs) which use different anode and cathode materials. The electrodes for supercapacitors should have high surface area per unit weight, high electrical conductivity and capacitance and be physically resilient so that these do not degrade during operation. Most of the research in asymmetric supercapacitors so far focus on metal oxide materials, but the oxides do not have particularly high electrical conductivity and become unstable when operated over long cycles.

Dr Huang Hui from A*STAR's Singapore Institute of Manufacturing Technology, working in collaboration with research teams from Nanyang Technological

University and Jinan University, China, has fabricated flexible asymmetric supercapacitors with metal-nitride electrodes on stacked graphene nanosheets (GNS) for the first time. The team used the atomic layer deposition (ALD) process to place two different materials on vertically aligned graphene nanosheets: titanium nitride for their supercapacitor's cathode and iron nitride for the anode. ALD is a precision method for creating thin-films that enabled the researchers to make the maximum use of the graphene surface.

The flexible all metal nitrides ASCs can cycle 20,000 times and exhibit both high capacitance and high power density. These improvements are due to the chemical stability of metal nitrides

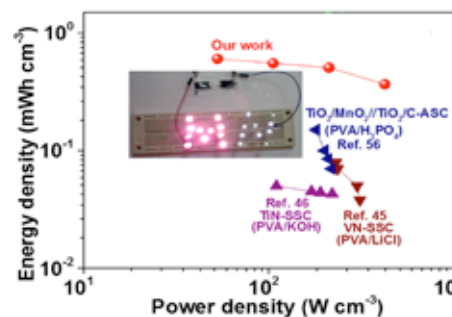

Performance of metal nitride ASCs. [1]

and ultra-high surface area of the vertically aligned graphene substrate and the ALD method that enables full use of it.

The flexible solid-state ASCs, typically small in size, highly reliable, lightweight, and easy to handle can provide high density and long cycling life.

The work has been published by *Advanced Materials* in August 2015 [1].

The flexible ASCs hold great promise as new energy storage devices for next-generation portable and flexible electronics such as wearable devices

For more information, please contact **Dr Huang Hui** at hhuang@SIMTech.a-star.edu.sg

[1] C. R. Zhu, et al., *Adv. Mater.* 27, 4566-4571 (2015)

A number of events were organised in 2016 to engage the industry and forge partnerships

SIMTech Annual Manufacturing Forum (AMF) 2016, 13 July

The SIMTech flagship conference attracted 245 attendees from industry, associations, government agencies and institutes of higher learning. With the theme Lightweight Materials: Trends, Applications and Opportunities for Manufacturing, the 11th SIMTech AMF'16 promotes lightweight technologies for local SMEs to harness the potential for new business opportunities.

The Workforce Development Agency of Singapore and Employment and Employability Institute are partners of this event in collaboration with the Singapore Manufacturing Federation and Singapore Precision Engineering and Technology Association.



Prof Alan Taub, Chief Technology Officer, LIFT (Lightweight Innovations for Tomorrow) and Mr Koichi Nakamura, Manager, Manufacturing Technology Research Department, Research & Innovation Centre, Mitsubishi Heavy Industries Ltd, Japan presented the Annual Manufacturing Lectures. The technical sessions focused on Polymer & Composites and Light Metals & Alloys. The event was complemented by an exhibition on products, services, solutions and training related to lightweight materials.



SIMTech-WDA PE WSQ Graduation Ceremony 2016, 3 August

552 participants from about 200 companies who have successfully celebrated their completion of their respective SIMTech-WDA Precision Engineering (PE) Workforce Skills Qualifications (WSQ) training programmes at a joint graduation ceremony. Dr Gog Soon Joo, Group Director, Training Partners Group from the Workforce Development Agency of Singapore, graced the occasion.

Winners of this year's Most Inspiring Trainee Award are Ms Lim Sock Siang, Manager, A & One Precision Engineering; Mr Teu Chihua, Senior Technical Officer, Setsco Services Pte Ltd and Mr Ng Yoke Some, General Manager (Trade, Operations and Treasury) Kian Ann Districentre Pte Ltd.

The Best Industry Partner Award is won by Toshiba TEC Singapore Pte Ltd, Megachem Limited and Molex Singapore.



EAC Inaugural Annual Conference 2016, 25 August

Prominent industry leaders and academic experts shared their insights on technology development and commercialisation opportunities in microfluidics, particularly in lab-on-a-chip for diagnostic applications. An array of microfluidics/lab-on-a-chip technologies, services, products and related businesses as well as competencies of SIMTech Microfluidics Foundry (SMF) was showcased at the event.

Topics covered at the conference include the Outlook of Microfluidics and Diagnostics Market, as well as Microfluidics Devices and Applications.

246 representatives from industry attended the event.

Collaborative Industry Projects (CIPs) are cost-effective R&D platforms, where companies facing similar issues work jointly with SIMTech, to develop manpower and technology



3D Additive Manufacturing Capabilities of Metal and Polymer

Call for Participation

This CIP aims to demonstrate process capability from design & process optimisation, material preparation & handling, product processing to secondary operations; to provide a platform for quicker adoption of 3D AM technology by leveraging on SIMTech's know-how and facilities.

For enquiries, please contact **Mr Tan Lye King** at tanlk@SIMTech.a-star.edu.sg

Advanced Machining Dynamics Analysis Technology

Call for Participation

This CIP aims to enhance the machining productivity and quality of local manufacturing industry in precision machining of steel and non-ferrous metals through technology transfer and customisation of quick dynamic milling toolkit to achieve chatter- and vibration-free machining.

For enquiries, please contact **Dr Mehrdad Zarinejad** at mehrdad@SIMTech.a-star.edu.sg

Collection Delivery Management System (CDMS)

Call for Participation

This CIP aims to use a mobile NFC/barcode-based solution to ensure right items are collected and delivered to the right customer and on time

For enquiries, please contact **Mr He Wei** at wh@SIMTech.a-star.edu.sg

Engineering Design for Manufacturing

Call for Participation

This CIP aims to help companies develop capabilities in engineering product design assessment for Engineering Design for Manufacturing objectives.

For enquiries, please contact **Ms Wan Siew Ping** at spwan@SIMTech.a-star.edu.sg

Inventory Tracking System

Call for Participation

This CIP aims to help companies deploy a RFID/barcode-based Inventory Tracking System (ITS) to better manage, track and stock take inventory to improve productivity, traceability and minimise errors.

For enquiries, please contact **Mr He Wei** at wh@SIMTech.a-star.edu.sg

Maintenance Management System (MMS)

Call for Participation

This CIP aims to enhance productivity and competitiveness for SMEs, especially in engineering service, construction and high value equipment manufacturing environment for better management of the maintenance activities and information. MMS can reduce machine downtime, maintenance costs, analysis time and provide quick maintenance decision support.

For enquiries, please contact **Mr Wong Ming Mao** at mmwong@SIMTech.a-star.edu.sg

Project Resource Tracking

Call for Participation

This CIP aims to use RFID technology and mobile devices with GPS to provide a cost-effective solution for companies to better manage the process and costs of their projects by providing accurate and timely identification and tracking of actual resource used.

For enquiries, please contact **Mr Wong Ming Mao** at mmwong@SIMTech.a-star.edu.sg

SMC Annual Conference 2016

3 November 2016 | 9.00am - 4.00pm

Devan Nair Institute of Employment and Employability, Halls 1, 2 & 3

The upcoming conference lines up an exciting array of presentations in the areas of **Resource Efficiency in Manufacturing Opportunities and Challenges**; **Life Cycle Engineering** and **Material Efficiency** as well as **Water Management**. Book your calendar to gain insights in these sustainable matters from the experts.

For enquiries, please contact **Mr Lee Hock Wee** at hwlee@SIMTech.a-star.edu.sg



Scan for more events

PE WSQ Graduate Diploma in Metal Manufacturing Processes

Module 5: Perform Advanced Metal Welding

17 October 2016 | 6.30pm - 9.30pm, Fusionopolis Two

PE WSQ Graduate Diploma in MedTech Manufacturing

Module 5: MedTech Device Design Innovation & Development

19 October 2016 | 6.30pm - 9.30pm, Fusionopolis Two

PE WSQ Graduate Diploma in Manufacturing Operations Management (MOM)

Module 5: Inventory Management

24 October 2016 | 6.30pm - 9.30pm, Fusionopolis Two

PE WSQ Operations Management Innovation Lean Improvement Towards Excellence (OMNI-LITE) - Nov Batch

1 November 2016 | 8.30am - 12.30pm, Fusionopolis Two

PE WSQ Graduate Diploma in Advanced Welding Technologies

Module 3: Review Welding Operation & Quality Control

3 November 2016 | 6.30pm - 9.30pm, Fusionopolis Two

PE WSQ Graduate Diploma in Precision Measurements Characterisation

Module 3: Precision Measurements

5 January 2017 | 6.30pm - 9.30pm, Fusionopolis Two

PE WSQ Graduate Diploma in Mechatronics

Module 1: Design Precision Machines

16 January 2017 | 6.30pm - 9.30pm, Fusionopolis Two

For course details and registration, please visit <http://kto.SIMTech.a-star.edu.sg>

For general enquiries, please contact
Tel: 6501 1800 | Email: kto-enquiry@SIMTech.a-star.edu.sg



Scan for more courses

Editorial Committee

Dr John Yong	Advisor
Ms Lee Swee Heng	Editor
Ms Lin Jiamin	Member
Dr Goh Kiah Mok	Member
Mr Peter Shi	Member
Ms Connie Ng	Member
Mr Larry Lim	Member
Mr Kelvin Goh	Designer

About SIMTech

The Singapore Institute of Manufacturing Technology (SIMTech) develops high-value manufacturing technology and human capital to enhance the competitiveness of Singapore's manufacturing industry. It collaborates with multinational and local companies in the precision engineering, medtech, aerospace, automotive, marine, oil & gas, electronics, semiconductor, logistics, and other sectors.

SIMTech is a research institute of the Agency for Science, Technology and Research (A*STAR). With a pool of more than 400 researchers, we are committed to serving the manufacturing industry to develop the human, intellectual, and industrial capital in Singapore.

